

# HI 1734-WS

## POINT I/O Weigh Scale Module



### *Installation & Operations Manual*



9440 Carroll Park Drive  
San Diego, CA 92121  
Phone: (858) 278-2900  
FAX: (858) 278-6700  
Web-Site: <http://www.hardysolutions.com>

## Local Field Service



### Hardy Field Service

Hardy Process Solutions provides local field service for all scales and weighing equipment. Hardy's factory trained technicians can perform service on all Hardy equipment as well as most other manufacturers' systems. Enabled by the Hardy Process Toolbox, our technicians spend less time onsite, saving you money and reducing your downtime.

Services Include:

- Installation & Commissioning
- Preventative Maintenance & Calibration
- Onsite Emergency Service
- Service Agreements with Defined Turnaround Times
- Product, Service, and PLC Integration Training
- Pre-Installation Site Audit
- Scale Installed-Base Evaluation
- PLC Integration Support
- Engineering Design Support & Specification Development
- Quality Documentation Creation

#### Contact Us

To request any of the services mentioned, or to discuss your needs with a trained Hardy Service Agent, please call 800-821-5831 Option 4 (6:30 AM to 5:30 PM PST). For emergency downtime service after hours, leave a message in our emergency mailbox and your call will be returned promptly. Or email us at [hardysupport@hardysolutions.com](mailto:hardysupport@hardysolutions.com).

# Contents



- CAUTION: UNPACK WITH CARE ..... 5
- ATTENTION: DÉBALLEZ SOIGNEUSEMENT..... 5
- Chapter 1 - Overview..... 6
  - Product Description..... 7
  - Waversaver® ..... 7
  - C2® Calibration ..... 7
- Chapter 2 - Specifications..... 9
  - Specifications..... 9
  - Environmental Requirements..... 9
  - Default Parameters ..... 10
- Chapter 3 - Installation ..... 11
  - Installation Overview..... 11
  - Detailed Installation Procedure..... 11
  - Load Sensor Connections ..... 12
- Chapter 4 – Setup and Operation..... 19
  - Power Check ..... 19
  - Setting Up Communications between the PLC and HI 1734-WS..... 19
  - Configuration Parameters ..... 22
  - Configuration with AOP..... 23
  - Commands..... 23
  - Output Table..... 26
  - Input Table..... 26
- Chapter 5 - Calibration ..... 28
  - Pre-Calibration Procedures ..... 28
  - Electrical Check Procedures ..... 29
    - Load Sensor/Point Input/Output Measurements ..... 29
    - Load Check..... 29
  - Calibration Setup Procedures..... 30

- C2 Calibration ..... 33
- C2 Calibration Using Ladder Logic ..... 33
- C2 Calibration Using the Faceplate ..... 33
- Hard Calibration..... 35
- Hard Calibration Using Ladder Logic ..... 35
- Chapter 6 – Troubleshooting..... 36
- Return Codes ..... 36
- Chapter 7 - Hardy Installation and Commissioning..... 38
- Emergency Service and Support..... 38
- Appendix A ..... 39
- List of the Parameter IDs ..... 39
- Read/Write Parameters..... 39
- Read Only Parameters..... 39

## **CAUTION: UNPACK WITH CARE**

WHEN UNPACKING, DO NOT DISCARD THE PACKING CASE OR ANY PACKING MATERIAL UNTIL THE CONTENTS OF THE PACKING CASE ARE INSPECTED AND CAREFULLY COMPARED WITH THE SHIPPING DOCUMENTS.

IF ANYTHING IS UNSATISFACTORY, PLEASE NOTIFY HARDY IMMEDIATELY BY CALLING, FAXING OR E-MAILING TO:

Customer Support Department  
HARDY PROCESS SOLUTIONS  
9440 Carroll Park Drive, Suite 150 San Diego, California 92121

Phone: (800) 821-5831  
(858) 278-2900  
FAX: (858) 278-6700

E-mail: [hardysupport@hardysolutions.com](mailto:hardysupport@hardysolutions.com) Web Address: [www.hardysolutions.com](http://www.hardysolutions.com)

A RETURN MATERIAL AUTHORIZATION (RMA) NUMBER IS REQUIRED BEFORE RETURNING ANY DAMAGED PRODUCT. CALL THE CUSTOMER SUPPORT DEPARTMENT TO GET AN RMA NUMBER. HAVE READY YOUR COMPANY NAME, ADDRESS, TELEPHONE NUMBER, SERIAL NUMBER OF THE UNIT AND A BRIEF DESCRIPTION OF THE PROBLEM WHEN CALLING.

IN CASE OF DAMAGE DUE TO SHIPPING, NOTIFY THE DELIVERING CARRIER IMMEDIATELY FOR AN INSPECTION.

### **ATTENTION: DÉBALLEZ SOIGNEUSEMENT**

VEUILLEZ CONSERVER L'EMBALLAGE PENDANT L'INSPECTION DU PRODUIT ET COMPAREZ RIGOREUSEMENT AVEC LES DOCUMENTS ENVOYÉS.

VEUILLEZ ALERTER IMMÉDIATEMENT L'AGENCE DE LIVRAISON AU CAS OU DES DOMMAGES DUES A LA LIVRAISON SERAIENT PRÉSENTS.

Customer Support Department  
HARDY PROCESS SOLUTIONS  
9440 Carroll Park Drive, Suite 150 San Diego, California 92121

Phone: (800) 821-5831  
(858) 278-2900  
FAX: (858) 278-6700

E-mail: [hardysupport@hardysolutions.com](mailto:hardysupport@hardysolutions.com) Lien: [www.hardysolutions.com](http://www.hardysolutions.com)

UN NUMÉRO UNIQUE (RMA ou RETURN MATERIAL AUTHORIZATION) EST NÉCESSAIRE AFIN DE RENVOYER LE PRODUIT ENDOMMAGÉ. CONTACTEZ LE SERVICE-CLIENTELE AFIN D'EN OBTENIR UN. VEUILLEZ VOUS PRÉMUNIR DES INFORMATIONS SUIVANTES AVANT L'APPEL : NON DE L'ENTREPRISE, ADRESSE, NUMÉRO DE TELEPHONE, NUMÉRO DE SÉRIE DU PRODUIT, AINSI QU'UNE COURTE DESCRIPTION DU PROBLEME.

## Chapter 1 - Overview

This manual is designed for use by installers, operators, and service personnel. It provides specifications and procedures for linking, configuring, operating, maintaining, and troubleshooting the Hardy Process Solutions HI1734-WS POINT I/O Weigh Scale Module. The system is used for front end signal processing of load cells and load sensors (strain-gage type sensors) for all types of industrial manufacturing weighing applications through an Allen Bradley 1734 POINT I/O chassis.

Modules feature Waversaver®, C2® Calibration, INTEGRATED TECHNICIAN™ (IT) diagnostics, and ladder logic configurability.<sup>1</sup>

Before using the product, be sure you understand all cautions, warnings, and safety procedures stated or referenced in this manual. And, to get the best service from this product, follow the practices recommended in this manual.

Hardy Process Solutions appreciates your business. We welcome all corrections or suggestions for improvement of this manual. Should you not understand any information in this manual or experience any problems with the product, please contact our Customer Support Department at:

Phone: (858) 278-2900

FAX: (858) 278-6700

e-mail: [hardysupport@hardysolutions.com](mailto:hardysupport@hardysolutions.com)

Web: [www.hardysolutions.com](http://www.hardysolutions.com)



---

<sup>1</sup> Waversaver® and C2® are registered trademarks and INTEGRATED TECHNICIAN™ is a trademark of Hardy Process Solutions.

## Product Description

HI1734-WS Weigh Scale Modules are self-contained, microprocessor-based I/O modules that produce weight data when connected to strain gauge load sensors (load cells, load points, platform scales), and are plugged into an Allen-Bradley Point I/O System.

The Allen-Bradley Point I/O® manual contains useful information about POINT I/O products that is not provided in this manual. This manual assumes that users have a basic understanding of process control and can interpret ladder logic instructions as needed to generate the electronic signals that control their application(s).

The HI1734-WS Weigh Scale Modules can be used for a wide variety of process weighing applications such as batching, blending, filling/dispensing, check weighing, force measurement, level by weight and weight rate monitoring.

The analog-to-digital converter in the weighing module controller updates 70 times per second and is capable of up to 8,388,608 counts of resolution. This is enough to provide accurate weight measurement and control and tolerate large “dead” loads or over sizing of load sensors.

## Waversaver®

During the measurement of small weight changes, the effects of mechanical vibration and noise from the operating environment can introduce substantial interference. Waversaver factors out vibration, noise, and other interference-related signals from the load cell so the rate controller can better compute the actual weight data.

Waversaver® can be configured to ignore noise with frequencies as low as 0.25 Hz. One of five higher additional cut off frequencies may be selected to provide a faster instrument response time. The default factory configuration is 1.0 Hz vibration frequency immunity. The five cutoff frequencies are: 0.25Hz, 0.5Hz, 1Hz, 3.5Hz and 7.5Hz.

## C2® Calibration

Traditional calibration uses certified test weights. C2® Electronic Calibration allows a scale to be calibrated without the need for test weights.

A C2 weighing system consists of up to eight C2 load sensors, a junction box, interconnect cable, and an instrument with C2 capabilities. Each Hardy C2-certified load sensor outputs digital information used for the calibration. The modules read the sensor outputs and detect the number of active sensors. It then calibrates the scale based on the load sensor's output plus a user-supplied reference point value (from 0 to any known weight on the scale).

## IT

INTEGRATED TECHNICIAN™ (IT) is a system diagnostics utility which, in conjunction with an HI 6010IT or HI 6020IT junction box, continuously monitors the excitation circuit (with up to 4 load sensors for the 6010 and up to 8 load sensors for the 6020) for possible malfunctions. IT reads individual load sensor voltages and weights and isolates individual system components for quick and easy troubleshooting.

If you do not have the HI 6020IT or HI 6010IT Junction Box connected to the module, the mV/V reading is displayed as the total for all the load sensors on the system.

### Return to Zero Test – Optional

This test requires the HI 6020IT or HI 6010IT Series Junction Box to monitor individual load sensors. It compares the original voltage reading (saved at calibration) against the current voltage reading of an empty vessel. The test checks for damaged load sensors due to electrical zero shift or abnormal mechanical forces that cause binding on one or all of the load sensors in the system.

**NOTE:** *The HI 1734-WS IS compatible with the Hardy HI 6020IT, HI 6020JB HI 6010 IT or HI 6010JB. You must use the HI 6020IT or the HI 6010IT to run this particular test. The HI 1734-WS is not compatible with the Hardy HI 215IT Junction Box. It is compatible with the HI 215JB without the IT functions.*

### Weighing System Test – Optional

For full utilization, this test requires the HI 6020IT or the HI 6010IT Series Junction Box. The Weighing System test is used to diagnose drifting or unstable weight reading problems. The Weighing System Test does the following:

1. Disconnects the load sensors and engages an internal (in the junction box) reference signal to see if the cable between the instrument and the Junction Box is causing the problem.
2. Reads the weight of each load sensor to see if the load sensor might be causing the problem.

The ability to read the weight seen by each individual load sensor allows use of this test to make cornering, leveling and load sharing adjustments to the weighing system.

### Auto Zero Tracking

Auto Zero Tracking automatically adjusts for zero weight. This capability allows the module to ignore material build-up in the weighing system within a pre-set auto zero tolerance. For auto zero to work, the current gross weight must be within the auto zero tolerance. The current gross, plus any previously zeroed weight must be within the Zero Tolerance level value and the scale must not be in motion. This is not used on all applications and should be reviewed before use.

**NOTE:** The amount of weight zeroed off is cumulative. The Auto Zero command will not run if the current gross weight plus any previously zeroed amount exceeds the zero tolerance value.



## Chapter 2 - Specifications

Chapter 2 lists the specifications for the HI1734-WS Weigh Scale Module. Specifications are listed for the standard instrument and for optional equipment. The specifications listed are designed to assist in the installation, operation and troubleshooting of the instrument.

### Specifications

Channels:	1
Conversion Rate:	55 updates per second internally, 50 updates per second to PLC.
Averages:	1-255 User Selectable in single increments
Resolution Internal:	1:8,388,608
Input:	Up to eight (8) 350 ohm Full Wheatstone Bridge, Strain Gauge Load Sensors/Cells (5 volt excitation) on one scale (using two junction boxes with a TB-10 connector)
Non-Linearity:	0.001% of Full Scale
Waversaver®:	User Selectable <ul style="list-style-type: none"> <li>• Off</li> <li>• 7.50 Hz</li> <li>• 3.50 Hz</li> <li>• 1.00 Hz (Default)</li> <li>• 0.50 Hz</li> <li>• 0.25 Hz</li> </ul>
Backplane Electrical Ratings:	24 VDC, 100 mA 5 VDC, 100 mA
Cable lengths:	250 feet maximum of C2 authorized cable (Maximum of 8 load sensors) with IT Junction box.
Load Cell Excitation:	5 VDC
Isolation from digital section	1000 VDC minimum
C2 Calibration Output:	Isolation from digital section 1000 VDC minimum
Temperature Drift:	Less than 0.0004% of full scale per degree C for Cal- LO and Cal-HI reference points

### Environmental Requirements

Operating Temperature Range:	-20°C to 55°C (-4°F to 131°F)
Storage Temperature Range:	-40°C to 85°C (-40°F to 185°F)

Humidity Range: 0-90% (non-condensing)

Approvals: UL, CUL Ordinary Location

### Default Parameters

Configuration Table	Data Type	Defaults	Range	
Gravity Correction	FLOAT	1.0	.9-1.2	
Motion Tolerance	FLOAT	10.0	.0001-999999.99	
Zero Tolerance	FLOAT	10.0	.0001-999999.99	
Tare Weight	FLOAT	0.0	.0001-999999.99	
Reference Weight	FLOAT	0.0	.0001-999999.99	
Span Weight	FLOAT	1000.0	.0001-999999.99	
AutoZero Tolerance	FLOAT	10.0	.0001-999999.99	
Enable AutoZero Tracking	BYTE	0	0-1	0 – Off 1 - On
Metric	BYTE	1	0-5	0 – oz 1 – lb 2 – ton 3 – g 4 – kg 5 - t
Load Cell Sensitivity	BYTE	4	0-8	0 – 1.0 mV/V 1 – 1.5 mV/V 2 – 2.0 mV/V 3 – 2.5 mV/V 4 – 3.0 mV/V 5 – 3.5 mV/V 6 – 4.0 mV/V 7 – 4.5 mV/V 8 – 5.0 mV/V
Waversaver	BYTE	3	0-5	0 – Off 1 – 7Hz 2 – 3.5 Hz 3 – 1Hz 4 – 0.5Hz 5 – 0.25Hz
Num Averages	INT	10	1-255	

**NOTE:** THE HI1734 is **not** compatible with HI 215IT Junction Boxes. Please ensure that the HI1734 is installed with the HI6020IT, HI 6020JB, HI 6010IT or HI 6010JB Junction Boxes. It is compatible with the HI 215JB without the IT functions.

# Chapter 3 - Installation

Chapter 3 provides the recommended procedures for unpacking, cabling, interconnecting, configuring and installing the Weigh Scale Module. Users and service personnel should be familiar with this information before installing or operating the Weigh Scale module. If you experience any problems installing this equipment, contact Hardy Process Solutions Technical Support for assistance.

## Installation Overview

**WARNING - ELECTROSTATIC DISCHARGE MAY DAMAGE SEMICONDUCTOR COMPONENTS IN THE MODULE. DO NOT TOUCH THE CONNECTOR PINS.**

**ATTENTION – UNE DÉCHARGE ÉLECTROSTATIQUE PEUT ENDOMMAGER DES COMPOSANTS SEMI-CONDUCTEURS DANS LE MODULE. NE PAS TOUCHEZ LE CONNECTEUR.**

Observe the following handling precautions:

- Wear an approved wrist-strap grounding device when handling the module
- Touch a grounded object or surface to rid yourself of any electrostatic discharge prior to handling the module
- Handle the module from the bezel in front away from the connector. Never touch the connector pins.
- Do not install the module right next to an AC or high voltage DC module
- Route all the load voltage cables away from high voltage cables

## Detailed Installation Procedure

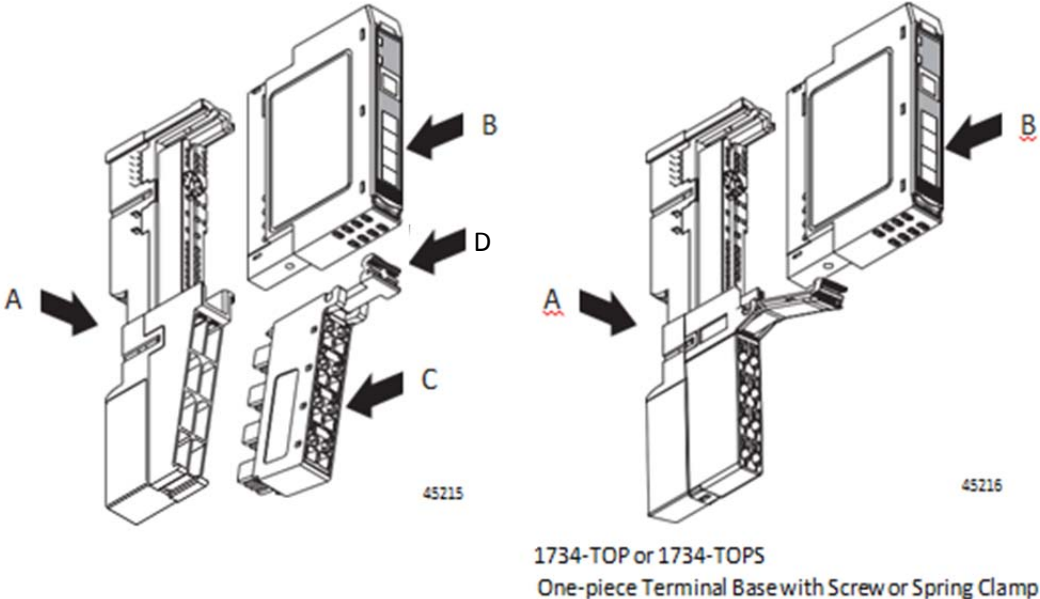

The base (A) mounts onto the DIN rail and provides the backplane. The HI1734-WS POINT I/O module (B) snaps into the base. The removable terminal block (C) also snaps into the base and provides the wiring and terminations for field-side connections, as well as system power for the backplane. For best performance, Hardy recommends use of 12-slot screw-down terminal. Spring clamp blocks are only recommended when using solid-core wiring.

To remove, simply move the Clip (D) into the downward position and pull the HI1734-WS out of the base.

For detailed installation instructions for the POINT I/O system, please visit:  
[http://literature.rockwellautomation.com/idc/groups/literature/documents/sg/1734-sg001\\_-en-p.pdf](http://literature.rockwellautomation.com/idc/groups/literature/documents/sg/1734-sg001_-en-p.pdf)



### Load Sensor Connections

The HI 1734-WS weigh scale module will need to be connected to external sensors, whether a single load sensor connected directly, a group of load sensors connected through a Junction Box or a platform scale such as a bench or floor scale connected direction. Each has its own wiring configuration.

Below are various connections for different types of sensors and different POINT I/O Terminal Blocks.

#### HI 1734-WS Weigh Scale Module Wire Terminations to Hardy Junction Boxes

##### SCREW DOWN TERMINALS RECOMMENDED

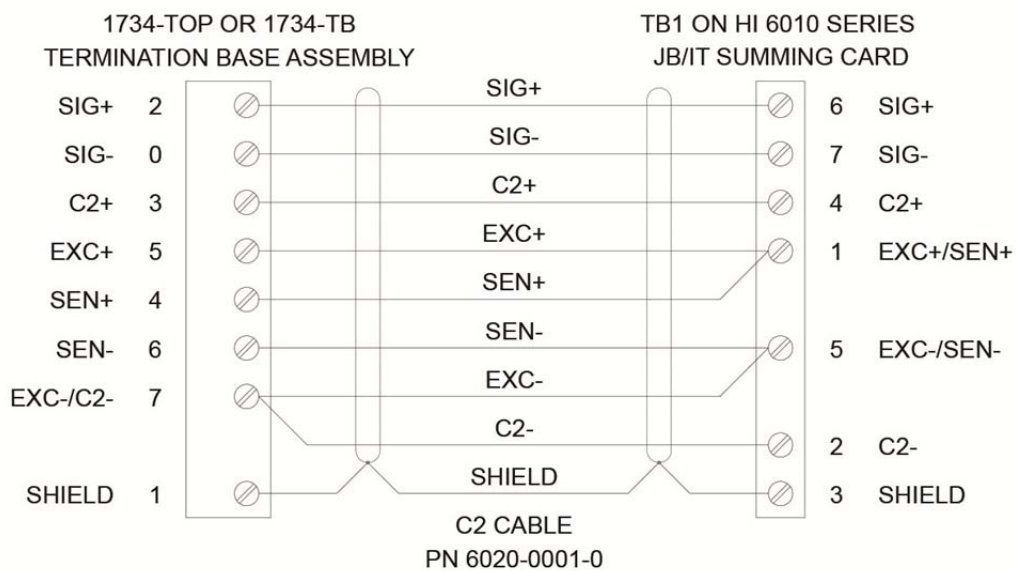

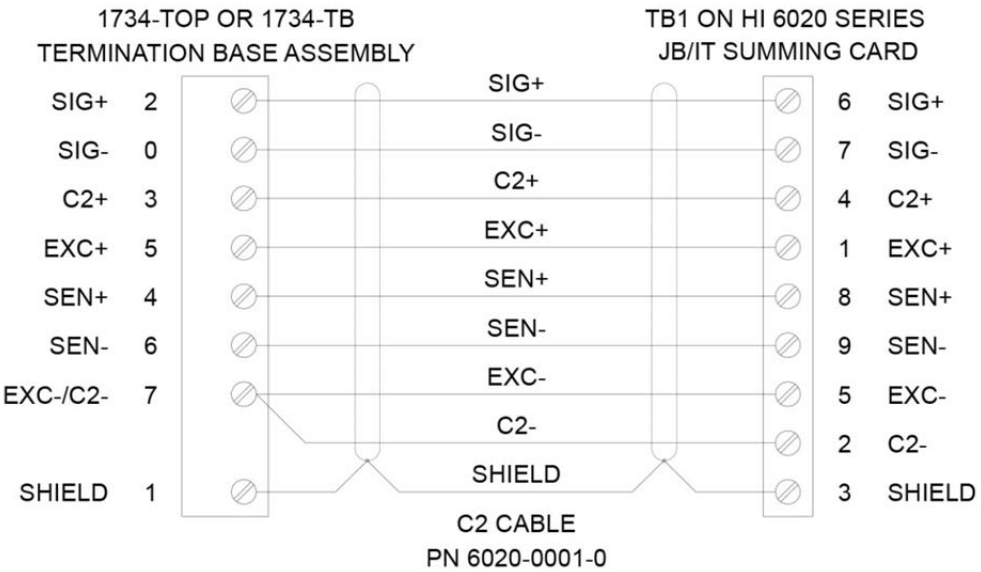

**HI 1734-WS Weigh Scale Module Wire Terminations to Load Sensors**

**SCREW DOWN TERMINALS RECOMMENDED**

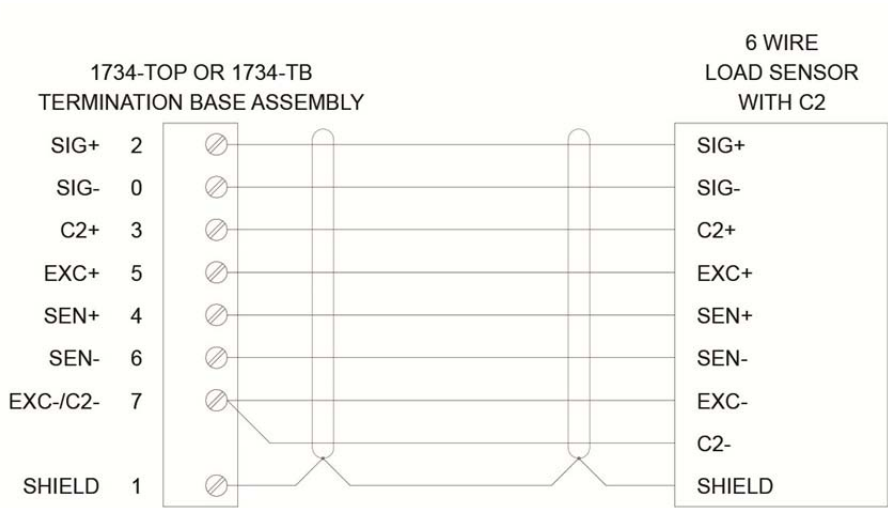

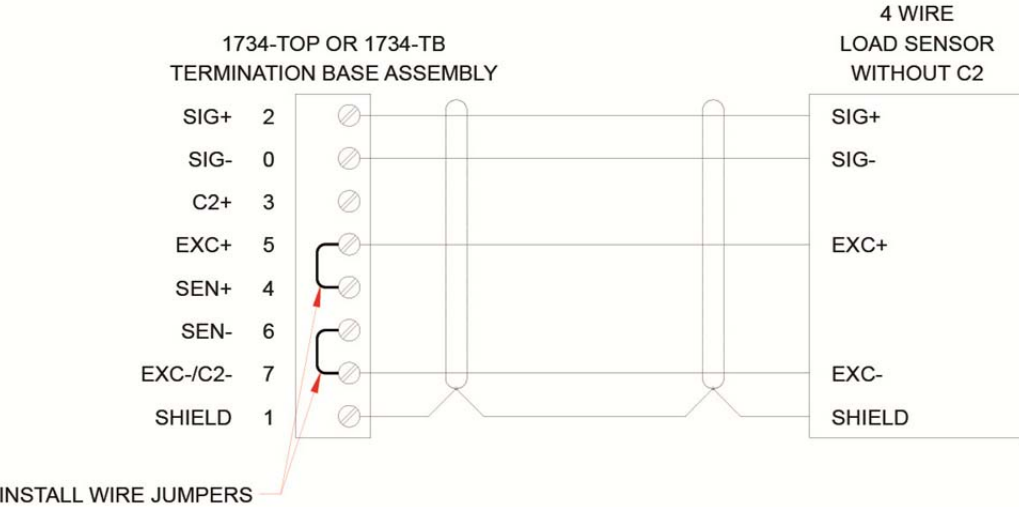
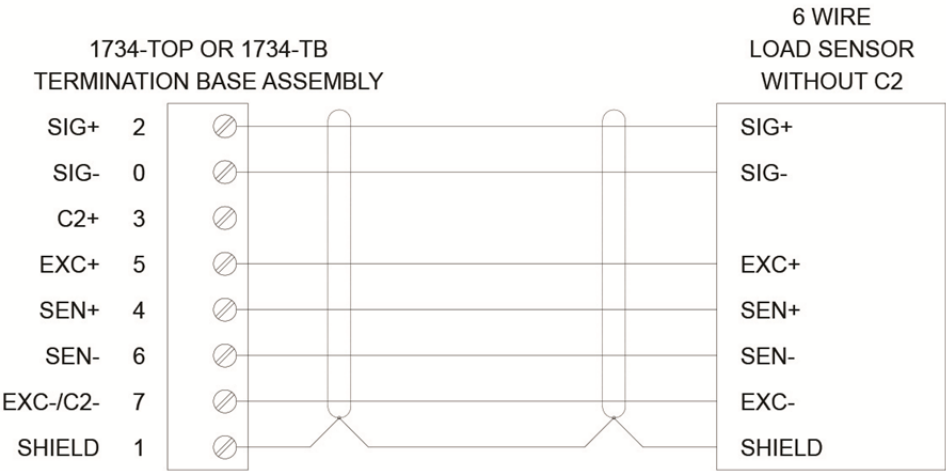
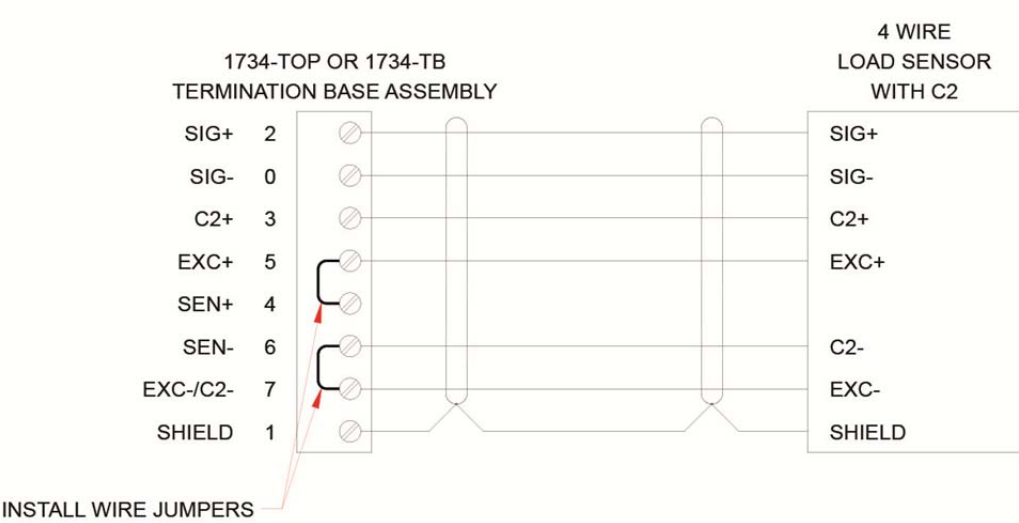

**HI 1734-WS Weigh Scale Module Wire Terminations to Hardy Junction Boxes**

**SCREW DOWN TERMINALS RECOMMENDED**

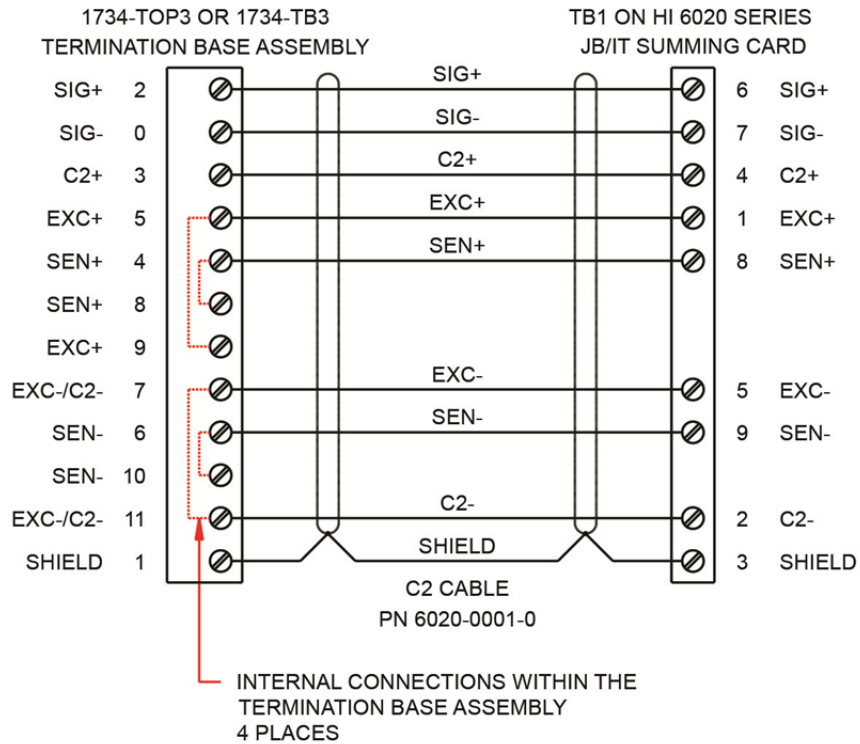
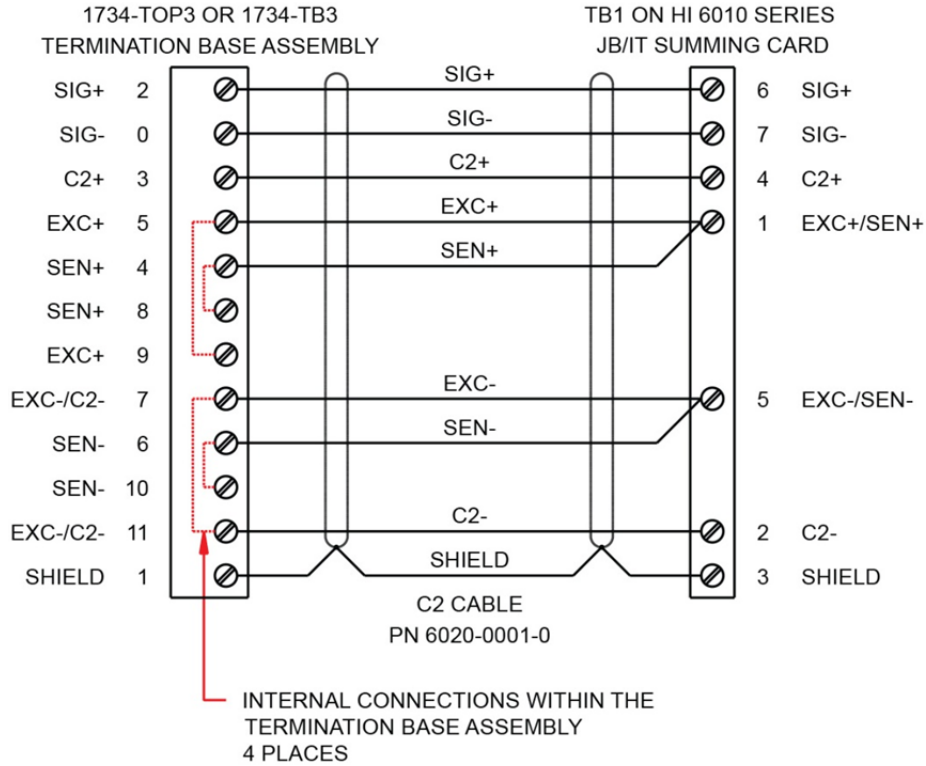

### HI 1734-WS Weigh Scale Module Wire Terminations to Load Sensors

#### SCREW DOWN TERMINALS RECOMMENDED

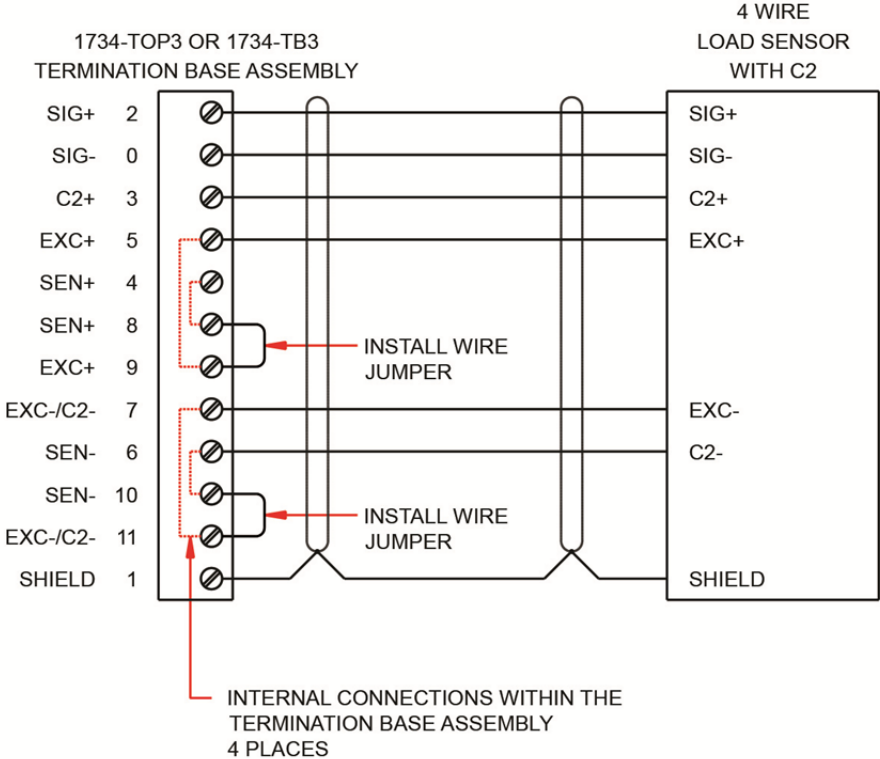
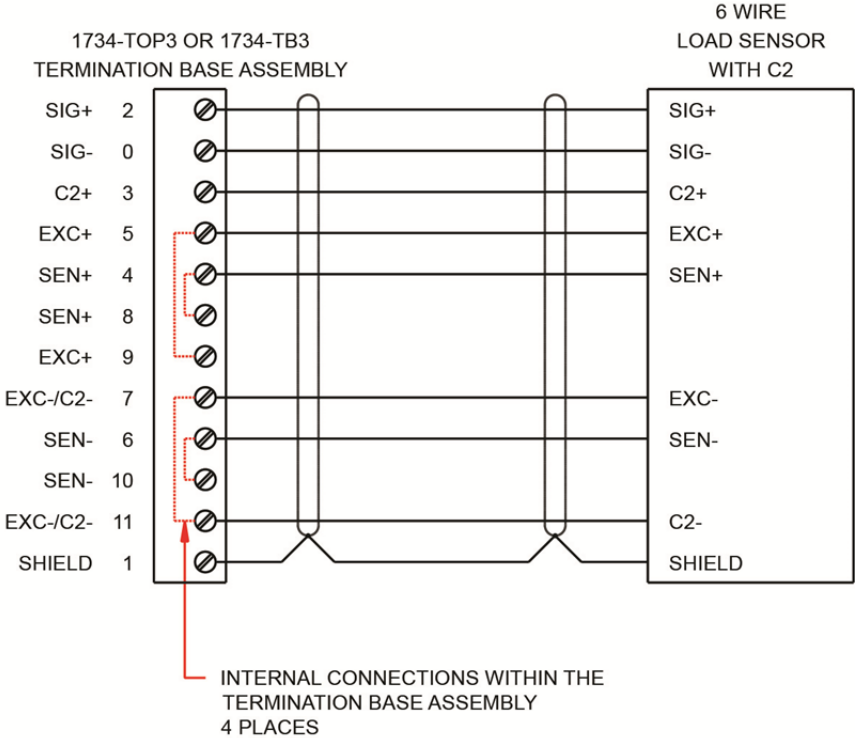



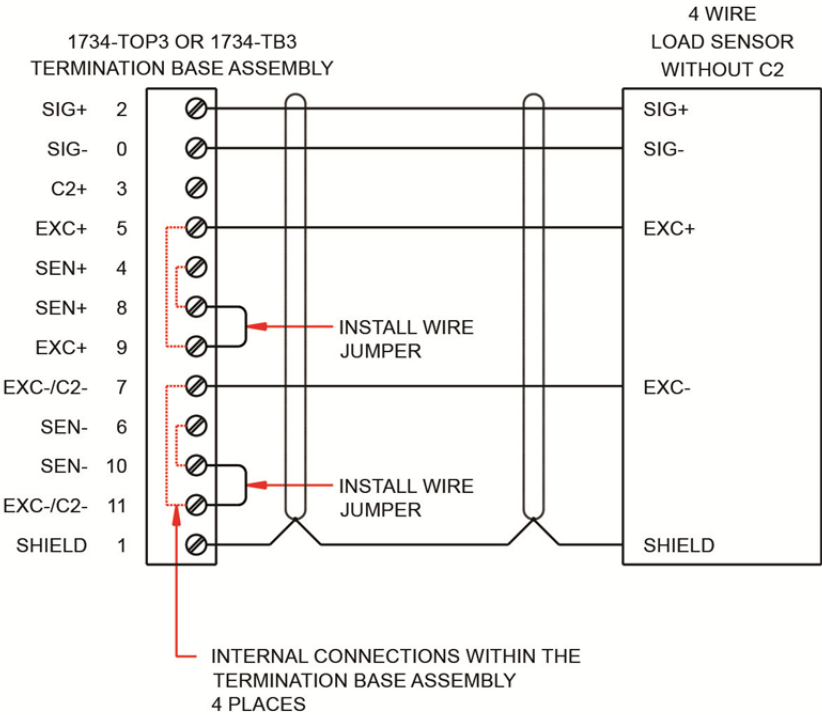
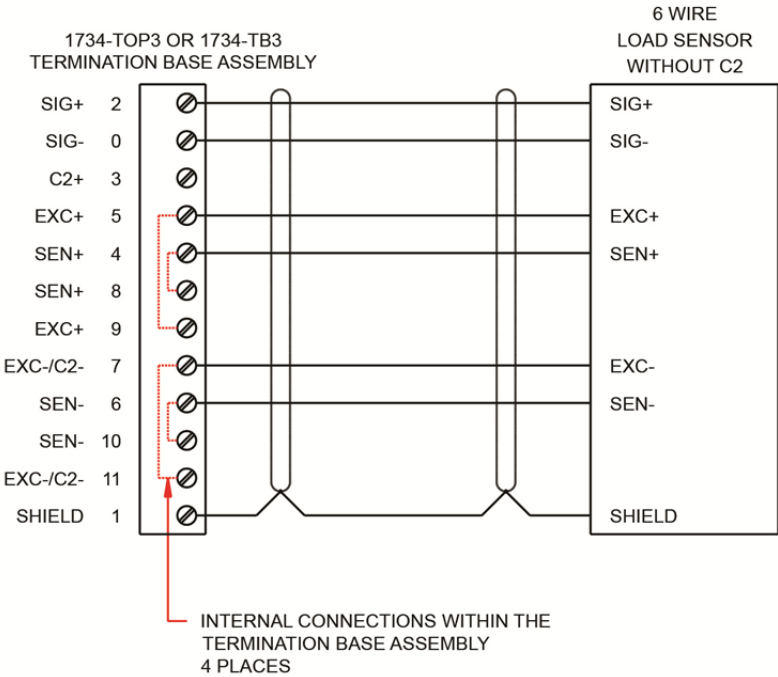

**Notes:**

- 1. If conduit is used, do not run load cell cable parallel to, or in the same conduit with power wiring, relay cable or other high energy cables.
- 2. When four wire load sensors with C2, and four wire load sensors without C2, are directly connected to the termination base assembly, wire jumpers must be installed in the termination base assembly where indicated.
- 3. Required load cell cable for C2 electronic calibration system and INTEGRATED TECHNICIAN: Hardy Process Solutions part number C2Cable (6020-0001-0).

4. 12-position 1734-TOP3 and 1734-TB3 screw lock type termination base assemblies have the following pins connected internally:
  - Pin 4 to pin 8
  - Pin 5 to pin 9
  - Pin 6 to pin 10
  - Pin 7 to pin 11
5. With 8-position 1734-TOP and 1734-TB screw lock termination base assemblies, only use stranded wire when connecting multiple wires into a single terminal point.
6. Termination base assembly screw lock wire size range: 14 AWG-22 AWG. Termination base assembly screw lock wire tightening torque: 7 lb-in [0.6nm] nominal.
7. 8 position 1734-TOPS and 1734-TBS types, and 12 position 1734-TOP3S and 1734-TB3S type, spring cage contact termination base assemblies may also be used, but are not recommended. If they are used, connect these termination base assembly types with 14 AWG to 22 AWG stranded wire.

## Chapter 4 – Setup and Operation

Chapter 4 covers the firmware and software settings used to prepare the module controller for calibration and operation. The Setup procedures require Allen Bradley's RS Logix 5000, Allen-Bradley RSLinx™ or RSLinx™ Lite.

### Power Check

To make or change settings, there must be power to both the PLC and the module. Verify that the LED's are lit for normal operation. (See Figure Below)

**Module Status**

LED Light	Status
Solid Green	Normal (Running)
Flashing Green	Device on standby (needs commissioning)
Solid Red	Unrecoverable Fault
Flashing Red	Minor Fault
Flashing Red/Green	Device Self testing
Dark - Off	No power to the module

**Network Status**

LED Light	Status
solid Green	On-line, connected
Flashing Green	On-line, not connected
Solid Red	Critical Link Failure
Flashing Red	Connection time-out
Flashing Red/Green	A specific communication faulted device
Dark - Off	Not Powered/Not Online

**Scale Status**

LED Light	Status
Steady Green	Running (Normal)
Flashing Green	Error No Calibration
Steady Red	Error Read Failure or Error Eeprom Write
Flashing Red	Read Convert Error

### Setting Up Communications between the PLC and HI 1734-WS

Follow these steps to set up communication between the ControlLogix PLC and the Weigh Scale Module. The steps require that you have a new or open RS Logix® 5000 project. For instructions, see your RS LOGIX 5000 manual.

When not plugged directly into certain compatible controllers, the HI 1734 WS point I/O module requires a communications adapter module. For this setup example/instructions, use the A-B 1734-AENT module.

- In the program Controller Organizer, find the I/O Configuration Section.
- Right click on the Ethernet Module you will be installing the Point I/O under.
- Select 'New Module' to display a list of modules.
- From the Catalog list, select the 1734-AENT module. Configure the module by:
  - Enter a unique name
  - Enter an IP address (Set up the addressing for the 1734-AENT module according to the instructions in the Rockwell manual.)
  - In the module definition, set the chassis size to the correct size for the number of modules you have, **including** the adapter module.

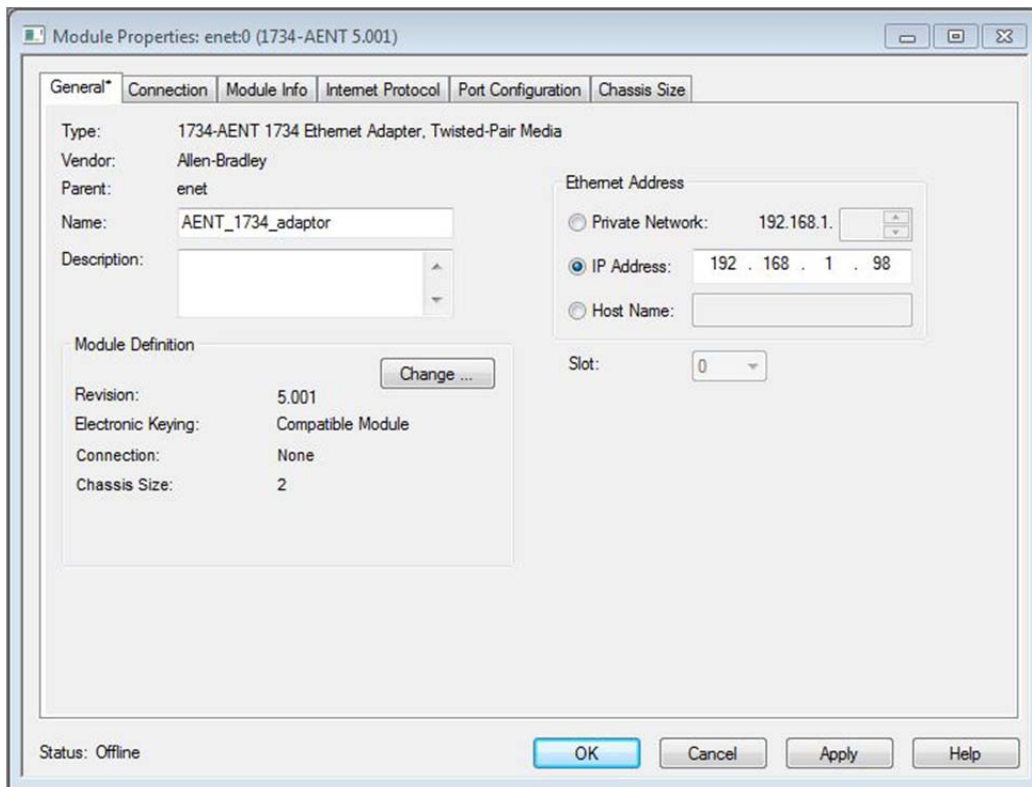

- Click OK to accept.
- Right click on the 1734-AENT module and select 'New Module'.
- Select the HI 1734-WS (1-Channel Weigh Scale). This will add the new module under the AENT adapter module

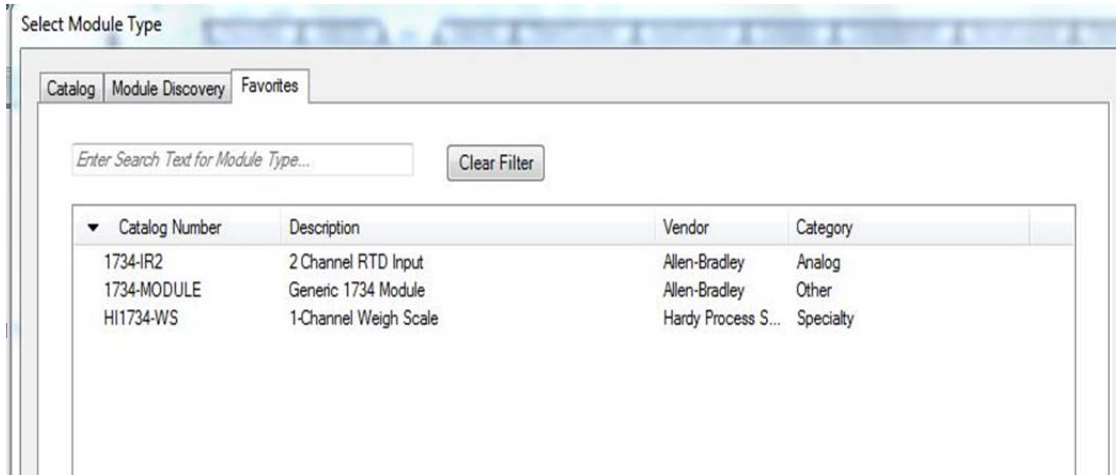

The module now shows in the controller Organizer in the I/O configuration under the Point I/O section. Repeat the above steps for any additional modules.

When setting up the HI 1734-WS module be sure to use an RPI (Requested Packet Interval) of 25 ms or greater (RPI  $\geq$  25 ms ) to avoid overloading the I/O adapters. For reference refer to Rockwell's Point I/O specification document.

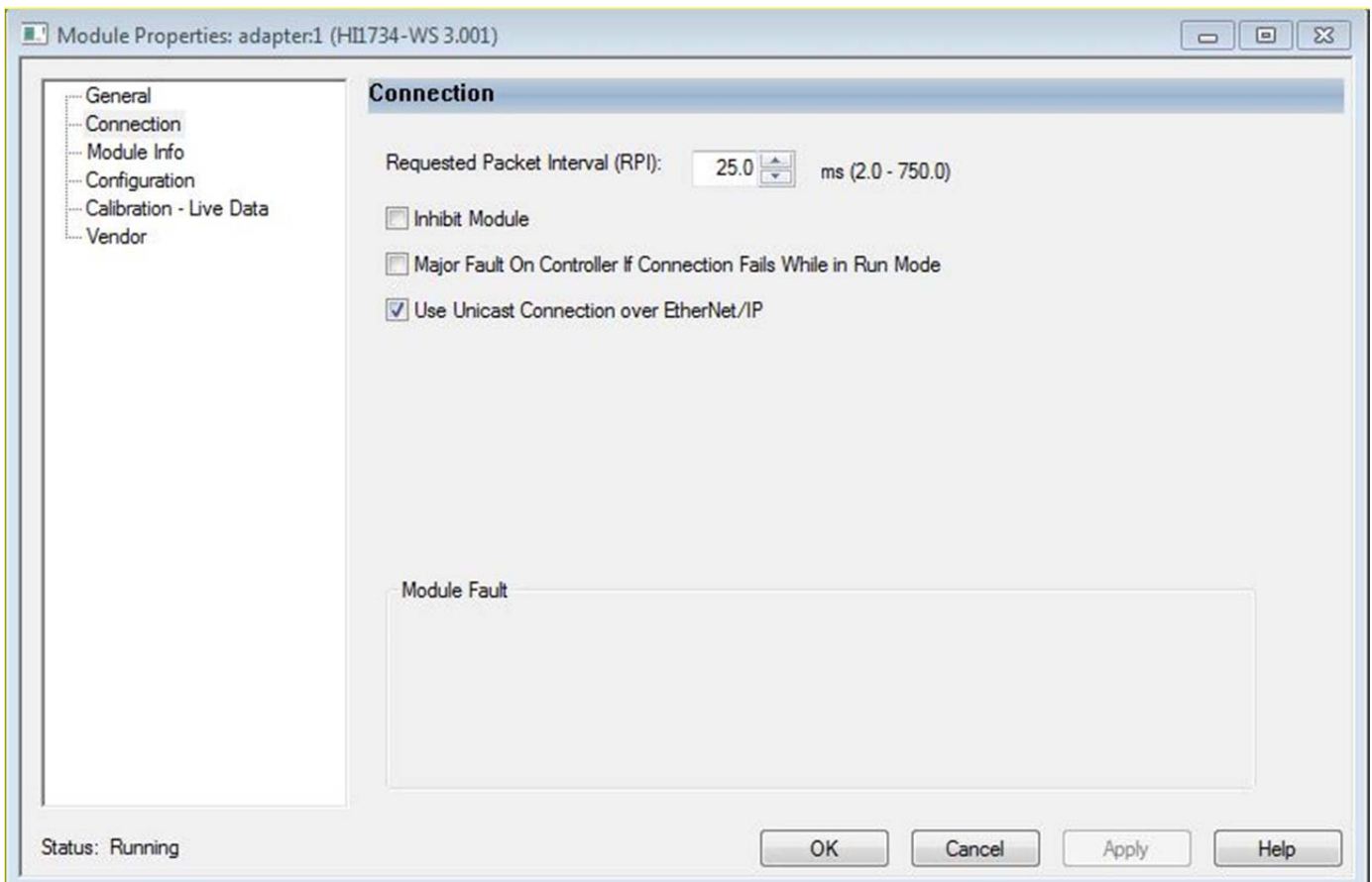

### Configuration Parameters

The following parameters are parameters used in the Configuration of the IO:

Configuration Parameters	Data Type
Gravity Correction	FLOAT
Motion Tolerance	FLOAT
Zero Tolerance	FLOAT
Tare Weight	FLOAT
Reference Weight	FLOAT
Span Weight	FLOAT
AutoZeroTolerance	FLOAT
Enable AutoZero Tracking	INT
Unit	INT
Load Cell Sensitivity	INT
WaverSaver	INT
Num Averages	INT

## Configuration with AOP

**Configuration**

Configuration Data

Units: lbs      WaverSaver: 3 Hz

Num Averages: 10

Motion Tolerance: 100.00 lbs      Tare Weight: 0.00 lbs

Zero Tolerance: 10.00 lbs      Auto-Zero Tolerance: 1.00 lbs

Enable Auto-Zero Tracking

Reference Weight: 0.00 lbs      Loadcell Sensitivity: 4.0 mV/V

Span Weight: 5.00 lbs      Gravity Correction: 1.10

Use with C2 Sensors

Status: Running

OK   Cancel   Apply   Help

Using the AOP to configure the HI 1734-WS module makes it fast and easy. First, open the AOP and navigate to Configuration. Make any required changes. Next, click on Apply. This will download the complete configuration table to the module. Once the table has been downloaded the module is automatically configured

## Commands

List of Hardy command Numbers

Command Number	Command
0	Read Parameter
1	Zero Cmd
2	Tare Cmd
(0x64) 100 dec	Cal Low Cmd
(0x65) 101 dec	Cal High Cmd
(0x66) 102 dec	C2 Cal Cmd
(0x80) 128 dec	IT Test
(0x94) 148	Set Default Parameters
(0x0100) 256 dec	IT Test Reduce
(0x0200) 512 dec	Stability Test
(0x1000) 4096 dec	Write Cmd
(0x10F0) 4336 dec	C2 Search

- **0: READ PARAM CMD.** To read a parameter, write a #0 to the CMD register (register #0), and write the parameter number in the ParameterID register of the output table. The parameter value may then be read from ParameterValue register in the input table. This value may be in integer or floating point format, depending on the parameter. The status register in the reply will contain the lower 16 bits of the system status word.
  - Status word bit 0: A/D error
  - Status word bit 6 (0x40): Motion status.
  - Status word bit 7 (0x80): Not Found - the requested parameter number does not exist
- **1: ZERO CMD.** Write a 1 to the command register to ZERO the gross weight. The status register will read 0 if this command succeeds.
  - Status Error code 1 (Fail)
  - Status Error code 2 (ADC Failure)
  - Status Error code 3 (out of tolerance)
  - Status Error code 4 (motion)
  - Status code FF (cmd in progress)
- **2: TARE CMD.** Write a 2 to the command register to ZERO the net weight. The status register will read 0 if this command succeeds:
  - Status Error code 1 (Fail)
  - Status Error code 2 (ADC Failure)
  - Status Error code 4 (motion)
  - Status code FF (cmd in progress)
- **0x64 (100 decimal): CAL LOW CMD.** Write a 0x64 hex to the command register to perform the low step of a traditional calibration. The status register will read 0 if this command succeeds:
  - Status Error code 1 (Fail)
  - Status Error code 2 (ADC Failure)
  - Status Error code 4 (motion)
  - Status code FF (cmd in progress)
- **0x65 (101 decimal): CAL HIGH CMD.** Write a 0x65 hex to the command register to perform the high step of a traditional calibration.
  - Status Error code 1 (Fail)
  - Status Error code 2 (ADC Failure)
  - Status Error code 4 (motion)
  - HardcalFailCounts 8: not enough counts between hard cal hi and hard cal lo
  - Status code FF (cmd in progress)
- **0x66 (102 decimal): C2 CAL CMD.** Write a 0x66 hex to the command register to perform a C2 calibration.
  - Status Error code 1 (Fail)
  - Status Error code 2 (ADC Failure)
  - Status Error code 4 (motion)
  - Status Error code 5 (no C2 cells)
  - Status Error code 6 (C2 capacities not equal)
  - Status Error code 7 (Non Hardy C2 load sensor)
  - Status code FF (cmd in progress)



- **0x80 (128 decimal): IT test.** Write a 0x80 hex to the command register to perform an Integrated Technician test. (Requires an IT summing card.)
  - Status Error code 1 (Fail)
  - Status code FF (cmd in progress)
- **0x94 (148 decimal): Set Default Parameters.** Write a 0x94 to the command register to set all parameters and calibration back to default settings.
  - Status Error code 1 (Fail)
- **0x100 (256 decimal): IT Test Reduced.** Write a 0x100 hex to the command register to perform an Integrated Technician test with reduced voltage. (Requires an IT summing card.)
  - Status Error code 1 (Fail)
  - Status code FF (cmd in progress)
- **0x200 (512 decimal): Stability Test.** Write a 0x200 hex to the command register to perform the stability test.
  - Status Error code 1 (Fail)
  - Status code FF (cmd in progress)
- **0x1000 (4096 decimal): WRITE CMD.** Set the value of a parameter. Write 0x1000 in the command register 0, the parameter ID number in ParameterID register and the desired value in ParameterValue register of the output table.
  - Status Error code 1 (Fail)
  - Status Error code 0x0B (Value out of range too high)
  - Status Error code 0x0C (Value out of range too low)
  - Status Error code 0x0D (Not allowed)
  - Status Error code 0x80 (Invalid parameter ID)
- **0x10F0 (4336 decimal): C2 Search.** Write 0x10F0 hex to the command register to force the module to search for and read/update C2 data.
  - Status Error code 1 (Fail)
  - Status code FF (cmd in progress)

#### Status Word Bits

- Bit 0 = A/D converter error - bad input from the load sensor.
- Bit 1 = A/D converter failure - no output from the converter to the processor.
- Bit 2 = Motion - indicates weight is in motion (changing).
- Bit 3 = EEPROM Write error - problem writing to the non-volatile memory in the unit.
- Bit 4 = Center of Zero
- Bit 5 = Saving to Non Volatile Memory.
- Bit 6 = Calibration in Progress
- Bit 7 = Error parameter ID Not Found
- Bit 8-15 = counter - The upper 8 bits are constantly incrementing. This constantly changing value can be used as confirmation of communications.

#### Command Status Return Value

- 0 = Success
- 1 = Fail
- 2 = Fail - ADC error
- 3 = Fail - out of tolerance
- 4 = Fail - motion
- 5 = Fail - no C2 load cells found
- 6 = Fail - C2 capacities not equal
- 7 = Fail - non Hardy C2 load sensor
- 8 = Fail - not enough counts between Cal low and Cal high weights

- 11 = Fail - value too high
- 12 = Fail – Value too low
- 13 = Fail – not allowed
- 128 = Fail – Parameter ID not found

## Output Table

Output Table for the AOP:

<b>OUTPUT table</b>	<b>Type</b>
Command	INT
Aux Command Information	INT
Parameter Value	DINT
Parameter ID	INT
Reserved word 1	INT
Reserved word 2	DINT
Reserved word 3	DINT
Parameter RD1 ID	INT
Reserved word 5	INT
Parameter RD2 ID	INT
Reserved word 6	INT
<b>Total</b>	<b>14</b>

Command, Aux Command Information, Parameter ID, and Parameter Value, are used to send commands to the instrument, write new parameter values, read existing parameter values, or read data values. The Command is a 16-bit value used for the command string as shown above in the command section.

The 16-bit Aux Command Information is used for specific information required for special commands. To select which parameter is being read or written, set the predefined number into the Parameter ID. If the value is being read, then the Parameter Value is ignored, or set to the required value if the value is being written.

The following values, Reserved 1, Reserved 2, Reserved 3, Reserved 4, Reserved 5, Reserved 6, and Reserved 7, are reserved, and also provide padding so the user selectable read only parameters are aligned between the output and input tables. The other two values Parameter RD1 ID and Parameter RD2 ID are user selectable parameter ID values which are used to read values from the instrument. These read values can be anything from an instrument specific measurement such as Num Averages to a parameter value such as Waversaver.

## Input Table

Input Table for the AOP:

<b>INPUT table</b>	<b>Type</b>
Command Echo	INT
Command Status	INT
Parameter Value	DINT
Parameter ID	INT
Instrument Status	INT
Net Weight	REAL
Gross Weight	REAL

Parameter RD1	DINT
Parameter RD2	DINT
<b>Total</b>	<b>14</b>

The first four variables in the input table, Command Echo, Command Status, Parameter ID, and Parameter Value, closely match the first four variables in the output table. The Command Echo is used to echo the command from the output table, to enable the PLC to ensure that the correct command has been executed; and also that the command status value is valid.

The Parameter ID; is an echo of the value sent in the output table, while the Parameter Value is the value for the specified Parameter ID. A 16-bit value, Instrument Status, provides the current state of all the major functions within the instrument. The top 8 bits are a cyclic “measurement update count”, which will increment by a count of one every time a new measurement value is taken, following a 0 to 255 then repeat cycle. If this value remains the same in two consecutive reads from the instrument then the communication or the measurement function has failed and the appropriate action needs to be taken. The bottom 8-bits reflect the status of all the major functions and should be used in conjunction with the “measurement update count” to determine the health of the instrument.

The Net and Gross Weight values are always provided. The final two read only command values Parameter RD1 Value and Parameter RD2 Value are the read only values for the different user selectable parameter ID values set in the output table. If a 0x0000 is placed in the Parameter RDx ID value, or the requested parameter does not exist a 0x0000 value will be returned.

## Chapter 5 - Calibration

Chapter 5 provides the recommended calibration procedure for the HI1734-WS Weigh Scale Module. For the module to work properly, it must be calibrated prior to operation, and it should be recalibrated periodically or when not in use for extended periods of time. Be sure to follow all the procedures completely to insure that the weights read by the module are accurate. Users and service personnel should be familiar with the procedures in this chapter before installing or operating the Weigh Module.

### Pre-Calibration Procedures

Verify that the load sensors have been properly installed.

- Step 1. Determine if the load sensors have been properly installed. See your load sensor's installation manual for proper installation instructions.
- Step 2. An arrow on some sensors and cells indicates the correct direction of the applied load, which is facing down. If the arrow points in the wrong direction, reposition the load sensor so the arrows are facing down.
- Step 3. Check for Binding on the Load sensor, mount or other parts of the weighing system.

**WARNING - BINDING ON A SCALE/VESSEL OR LOAD CELL DOES NOT ALLOW THE LOAD SENSOR FREE VERTICAL MOVEMENT AND MAY PREVENT THE INSTRUMENT FROM RETURNING TO THE ORIGINAL ZERO REFERENCE**

**ATTENTION – LIER SUR UNE ÉCHELLE / RÉCIPIENT OU CELLULE DE CHARGE NE PERMET PAS LA CELLULE DE CHARGE LIBRE CIRCULATION VERTICALE ET PEUT EMPÊCHER L'APPAREIL DE REVENIR AU POINT DE RÉFÉRENCE ZÉRO D'ORIGINE.**

Load sensors must be mounted so that 100% of the load (Vessel w/Contents) passes vertically through all the sensors comprising the system.

Verify that nothing is binding the load sensors. This means that nothing is draped across the scale/vessel or the load sensor, such as a hose, electrical cord, tubes, or other objects. Verify that nothing is in contact with the scale/vessel other than service wires and piping that have been properly mounted with flexible connections. Flexible pipes are not to be used in any other than the horizontal plane and are not to be used to correct pipe alignment problems. Vertical or at angles other than horizontal will have a negative effect on the scales ability to repeat and provide accurate weight readings.

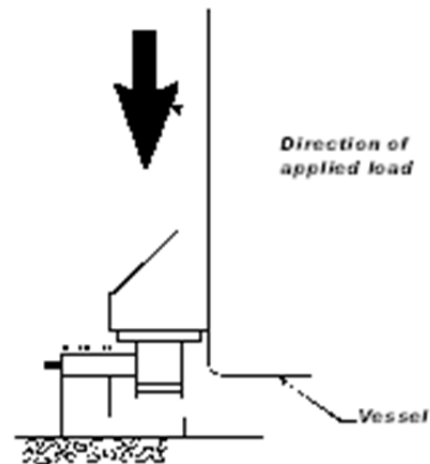

## Electrical Check Procedures

### Load Sensor/Point Input/Output Measurements

The HI 1734-WS module is designed to supply 5 VDC excitation to as many as eight 350-Ohm load cells/points per channel. The expected output from each load cell/point will depend on the mV/V rating of the load cell/point and the weight.

For example, a 2mV/V load sensor will respond with a maximum of 10 mVDC at the load sensor's full weight

capacity, which includes the weight of the vessel and the weight of the product as measured by the load cell/point. Thus, if the load sensor's weight capacity is rated at 1000 pounds, the load sensor will be 10 mVDC at 1000 pounds, 7.5 mVDC at 750 pounds, 5 mVDC at 500 pounds and so on.

A zero reference point will vary from system to system depending on the "Dead Load" of the vessel. "Dead Load" is the weight of the vessel and appurtenances only, with no product loaded. In our example we will assume the dead load to be 500 pounds.

**NOTE:** *The operating range for the scale in this example is 5-10 mVDC with a 500 pound weight range. After zeroing the instrument, the 0 reading refers to the zero reference point and not absolute 0 mVDC or absolute 0 weight.*

**NOTE:** *Load sensor measurements are checked with a digital voltmeter at the load cell connector on the front of the module or by using INTEGRATED TECHNICIAN with a Hardy IT Junction Box. The scale calibration must be completed to enable IT to function correctly.*

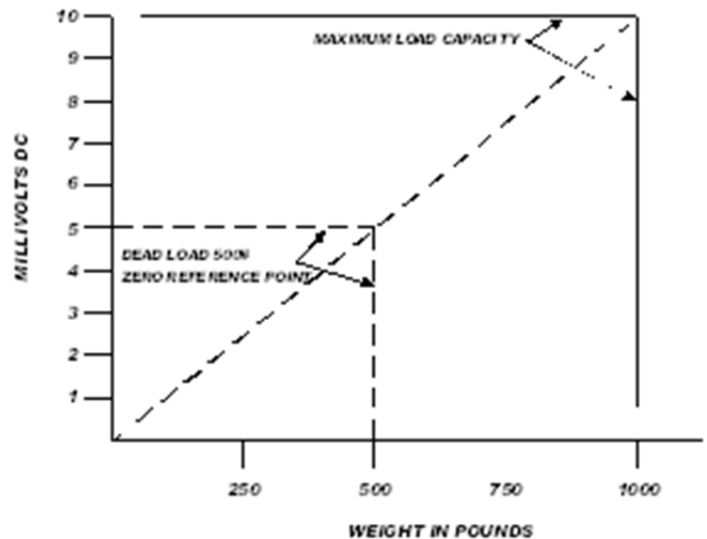

### Load Check

Place a load (weight) on the scale or vessel, and check to see if the weight reading on the input table changes in the proper direction.

For example, if the display reads 100 pounds and a 20-pound weight is placed on the vessel or scale, the display should read 120 or some value over 100. With the display reading 100 pounds, if a 20-pound load is placed on the vessel or scale and the reading is 80 pounds, the reading is going in the wrong direction and indicates some problem with the system.

If the display reads improperly or shows no change, something is wrong with the setup. If the display changes weight in the proper direction, remove the weight and proceed to calibrate the instrument. Refer to Chapter 7 on troubleshooting for additional help to determine the cause of the poor weight reading.

## Calibration Setup Procedures

### Unit of Measure

The Unit of measure can be set to ounces, pounds, tons, grams, kilograms, or metric tons. Any weight value input to the module (e.g. CALLOW WEIGHT, SPANWEIGHT) is in the currently selected units. The unit of measure can be set at any time, not just at calibration. Setting the unit of measure before calibrating reminds the user what unit of measure is being displayed.

It is important to note that the weigh scale module does not need to be calibrated again after changing the unit of measure.

### Motion Tolerance

The motion tolerance defines the amount the weight reading needs to change in a 1 sec period of time to make the scale go into MOTION status. If the change over the last 1 sec is less than the Motion Tolerance then the scale will not indicate in motion. "Motion Indicate" means the weight on the scale is currently changing. The scale cannot be calibrated, tared, or zeroed while in motion.

### Zero Tolerance

The Zero Tolerance sets the range of weights so that the Zero Command works as an offset of the calibrated Zero. The amount of weight zeroed off is cumulative. The zero command will fail if the current gross weight plus any previously zeroed amount exceeds the zero tolerance.

### Auto Zero Tolerance

When the Auto Zero Tolerance is entered and Auto Zero Tracking is enabled, any weight within the entered tolerance of zero and not in motion will cause the display to automatically read zero.

The amount of weight zeroed off is cumulative. The auto zero command will not run if the current gross weight plus any previously zeroed amount exceeds the zero tolerance or if the scale is in motion.

### Zero Track Enable

Enables the Auto Zero tracking if on or disables the auto zero when off.

### Number of Averages

The Number of Averages sets the number of weight readings which will be used to compute the displayed weight. The average is a sliding average so that a new average reading is available for display at every reading.

### Span Weight

The Span Weight is a Calibration high reference point derived from an actual measured weight. This should not be confused with the Scale Capacity. If you have a 100 pound weight and you place it on the scale, the Span Weight would be 100 pounds.

## Ref Weight

The Ref Weight is a Calibration low or C2 Cal reference point derived from an actual measured weight, normally zero.

## Gravity Correction

Objects weigh about 0.5% less at the equator than they weigh at each pole because the force of gravity is less at the equator than at the poles. For example an object weighing 100 pounds at the North Pole on a spring scale would weigh 99.65 pounds at the equator.

Depending on the latitude of your location, your scales would measure somewhere in between. The table below shows the gravitation correction factor for a few cities around the world.

**NOTE:** *Ensure that the scale system is clean and ready to receive product. This step establishes the gross zero reference. You must perform a C2 Calibration after setting the Gravity Correction or the correction factor won't work.*

In general if your location is between the 45th parallel and the equator, gravity correction is greater than 1.0. For example, at these latitudes, because the gravity is less, you are adding, 1.0006 for an error that is .06%). For locations between the 45th parallel and the North or South Pole your correction factor will be less than 1.0. For example .9994 for an error that is -.06%.

Gravity Correction compensates for an object weighing less at the equator than at the North or South Pole. This allows the user to enter the correction factory for their location and apply it for their C2 calibration. This is not used for the hard calibration.

City	Grav. Accel	City	Grav. Accel	City	Grav. Accel
Amsterdam	0.999369	Istanbul	1.000406	Paris	0.999048
Athens	1.000684	Havana	1.001872	Rio de Janeiro	1.001884
Auckland NZ	1.000782	Helsinki	1.001405	Rome	1.000326
Bangkok	1.002392	Kuwait	1.001405	San Francisco	1.000702
Brussels	0.999503	Lisbon	1.000615	Singapore	1.00269
Buenos Aires	1.001004	London	0.999445	Stockholm	0.99877
Calcutta	1.00191	Los Angeles	1.001028	Sydney	1.00104
Cape Town	1.00104	Madrid	1.000461	Taipei	1.001741
Chicago	0.99922	Manila	1.000461	Tokyo	1.000886
Copenhagen	0.999075	Mexico City	1.002102	Vancouver BC	0.999653
Nicosia	1.00093	New York	1.000433	Washington DC	1.000601
Jakarta	1.002631	Oslo	0.998726	Wellington NZ	0.999399
Frankfurt	0.999579	Ottawa	1.000007	Zurich	0.999821

## Tare Weight

The Tare weight is the amount of weight tared off with the last tare command or the amount entered by the user. The tare weight equals the difference between the net and gross weight readings.

## Waversaver®

There are 6 selectable levels. 0 provides NO vibration immunity with the fastest response time. 5 provides the most vibration immunity with the slowest response time. Default setting is 3.

Immunity	Setting
Off	0
7.5 Hz	1
3.5 Hz	2
1.0 Hz	3
0.50 Hz	4
0.25 Hz	5



**WARNING: BINDING ON A SCALE/VESSEL OR LOAD CELL CAN DENY THE LOAD CELL FREE VERTICAL MOVEMENT AND PREVENT THE INSTRUMENT FROM RETURNING TO THE ORIGINAL ZERO REFERENCE POINT.**

**ATTENTION: LIEU SUR UNE ÉCHELLE / UN BATEAU OU UNE CELLULE DE CHARGE PEUT ENDOMMAGER LE MOUVEMENT VERTICAL LIBRE DE LA CHARGE DE CHARGE ET ÉVITER L'INSTRUMENT DE RETOURNER AU POINT DE RÉFÉRENCE ZERO ORIGINAL.**

## C2 Calibration

C2 calibration requires C2 load sensors. If you do not have C2 load sensors you must perform a traditional calibration with test weights which we call a Hard Calibration. The Weigh Module reads the performance characteristics of each individual load cell and detects the quantity of load cell(s) in the system. C2 Calibration can be performed by via Allen Bradley RS LOGIX 5000.

### C2 Calibration Procedure:

- Step 1. Place the ref weight on the scale (if not zero).
- Step 2. Send the C2 calibration command (0x66) by placing the command number into the command register in the output table.

### C2 Calibration Using Ladder Logic

1. Check to be sure that the parameters have been setup for your weighting process. (See Chapter 4, Setup & Operations)
2. We have provided a Ladder Logix example explaining how to perform the C2 calibration. The Ladder Logix example is available on the Hardy Process solutions Web Site: <http://www.hardysolutions.com>
3. Under HI 1734-WS Docs and Programs

### C2 Calibration Using the Faceplate

Once the Faceplate is up and running (for faceplate set up refer to Faceplate quick start), navigate to the calibration menu of the faceplate. Be sure to set your reference weight to the weight that is on the scale (if there is weight on the scale, otherwise leave it at zero). Once the parameters are set make sure to save them, by clicking on the **Save Parameters** button. Now that the parameters are set you are able to perform a C2 Calibration by clicking on **Do C2 Cal**. The Calibration status will display once "Calibration Ok" once the calibration is finished.

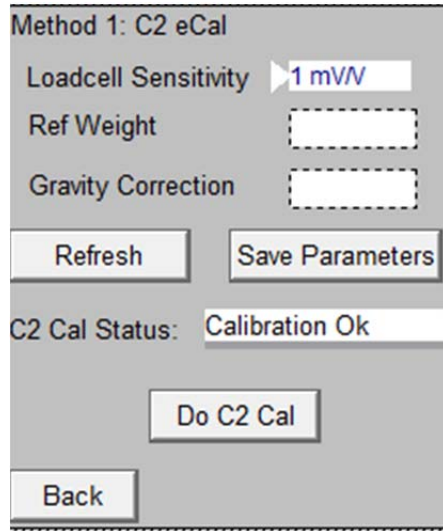

### C2 Calibration Using the AOP

Once the AOP is installed and configured, the AOP can be used to perform a C2 Calibration. Double click on the HI1734 that is located in the IO tree. The AOP window will pop up, next click on the Calibration – Live Data. From this window you can read the Reference Weight value that is used by the module to do the C2 calibration. When ready to perform C2 calibration just click on C2 Cal. At the bottom of the page, use the Command Status view the feedback on the execution of the command.

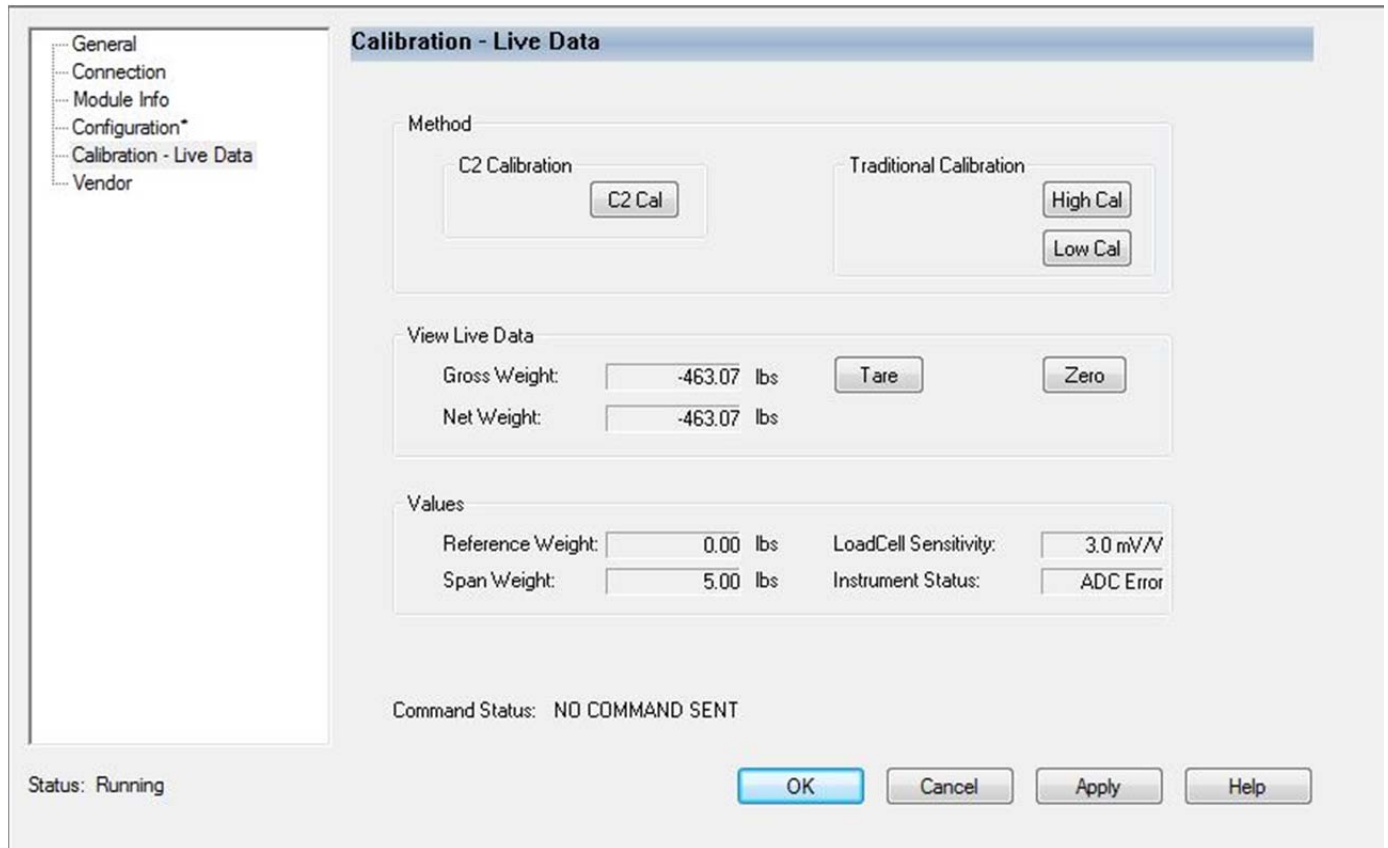

## Hard Calibration

Hard Calibration is the traditional method of calibration that uses test weights. Hardy recommends that the test weights total 80 to 100% of the scale capacity.

- |        |  |
|--------|--|
| Step 1 | Place the low calibration ref weight (the weight can be zero) on the scale   |
| Step 2 | Send a Cal Low Command (CALLOW- CMD) <ul style="list-style-type: none"> <li>• The Cal Low Command - sets the “calLowCount” parameter to the current A/D average counts when doing a hard calibration.</li> </ul> |
| Step 3 | If you used a weight remove it from the scale  |
| Step 4 | Place the high (Span) calibration weight on the scale  |
| Step 5 | Send a Cal High Command (CAL- HIGHCMD) <ul style="list-style-type: none"> <li>• The Cal High Command - Sets the Span Weight parameter to the current A/D average counts when doing Hard CAL</li> </ul>           |
| Step 6 | Remove the weight from the scale   |

### Hard Calibration Using Ladder Logic

- |        |  |
|--------|--|
| Step 1 | Check to be sure that the parameters have been setup for your weighing process. (See Chapter 4, Setup)   |
| Step 2 | We have provided a Ladder Logic example explaining how to set the weigh process parameters. The Ladder Logic example is meant to provide a ladder logic model only. Your application may vary and the example may or may not meet your requirements.                   |
| Step 3 | The Ladder Logix example is available on the Hardy Process solutions Web Site: <a href="http://www.hardysolutions.com">http://www.hardysolutions.com</a> Navigate to Products> PLC Weighing Modules > Weight Modules> HI 1734-WS Weigh Scale Module > Docs & Programs. |

## Chapter 6 – Troubleshooting

### Return Codes

Name/Code #	Definition	Action
<b>Command Success command Status 0</b>	Command passed	None
<b>Command fail Command Status 1</b>	Command Failed. Applies to pass/fail commands like C2 Search	Command specific. Reevaluate the command and conditions.
<b>ADC Convert error Command status error 2 Statusword bit 0</b>	Load Cell input out of range (i.e., voltage not 0-15 mV and flashing red LED will display). Can result from overloaded or mismatched load cell. In this state weight readings do not respond to changes.	Check the voltage levels to the module from each load cell. +5 V for excitation and sense lines and 0-15 mV on signal lines. If voltage is bad, to find a problem load cell, disconnect each one at the summing box.
<b>Statusword, bit 1 AC Convert Failure</b>	Output from the A/D converter to processor is bad. The module shows a solid red LED.	Contact Customer Support to return module for repair.
<b>Statusword bit 2 Status Motion Command status error 4</b>	The rate of scale weight change over 1 second exceeds the motion tolerance setting. If the setting is too low, motion may be indicated when no changes are occurring.	If the weight is actually changing, stabilize it. If not, increase the motion tolerance setting until the motion bit goes off with static weight.
<b>Statusword bit 3 EEPROM write error</b>	Module cannot write (save settings) to non-volatile memory. EEPROM is probably bad.	Contact Customer support to return module for repair.
<b>Statusword bit 4 Status Center Zero</b>	Indicates the gross weight is reading at the calibration zero point.	None
<b>Statusword bit 6 In Progress Command Status 0xFF</b>	Command is in progress.	None
<b>Statusword bit 7 not found Command Status 0x80</b>	The parameter ID is invalid	Correct the parameter ID
<b>Command Status 5 No C2</b>	When trying to do a C2 calibration, the module cannot read the data from the load cells.	Check the wiring to ensure proper connections and orientation. Find the problem load cell by disconnecting them at the summing box.
<b>Command Status 6 C2 Capacities not equal</b>	C2 load cells have unequal capacities due to either the use of mismatched load cells or faulty C2 programming.	Verify each load cell is correct per the spec sheet delivered with the cell.
<b>Command Status 7 C2 clones</b>	C2 load cell has a non Hardy C2 load	Verify the use of Hardy load cells.

	cell.	
<b>Command Status 8 Hard Cal Fail Counts</b>	Too few A/D counts between zero and span points during hard calibration. Input must change by a minimum amount between the cal low and cal high points.	Add weight to the scale and see if readings increase. Check voltages as in ADC Convert Error.
<b>Command Status 0x0B (11 dec)</b>	Value being set is too high	Verify the value is within the tolerance for the parameter being written to. Verify the parameter ID is the correct ID for the parameter you wish to write to.
<b>Command Status 0x0C (12 dec)</b>	Value being set is too low	Verify the value is within the tolerance for the parameter being written to. Verify the parameter ID is the correct ID for the parameter you wish to write to.
<b>Command Status 0x0D (13dec)</b>	<b>Value not allowed</b>	

## Chapter 7 - Hardy Installation and Commissioning

Hardy delivers on its reputation as a quality manufacturer of weighing equipment. Hardy solutions are EASY to install, integrate, commission, diagnose and maintain. Our customers find that this simplicity delivers the lowest total cost of ownership.

To ensure the best performance of Hardy products, we recommend that you add Hardy Installation to your product purchase. Great products without a quality installation risk long-term performance and availability, and Hardy has a broad network of trained service agents to perform, inspect, and commission new installations.

Hardy offers preferred rates for new installations and we guarantee that the installation will be done right the first time. Plus, with the use of the Hardy Toolbox features like C2 Electronic calibration, Hardy Technicians spend less time onsite than the competition, saving you cost and downtime.

For a fast and easy installation quote, please contact one our service specialists at:

**800-821-5831 option 4, or email us at: [hardysupport@hardysolutions.com](mailto:hardysupport@hardysolutions.com)**

### Emergency Service and Support

Even with the best quality equipment, failures can happen without warning. The question isn't "if" this will happen, but how prepared you are to rectify the situation "when" the unexpected happens.

Hardy Field Service Technicians are located nationwide to ensure the fastest response to your unplanned downtime, and our emergency after-hours mailbox is checked constantly to prevent customers experiencing a downtime event from having to wait until morning.

For rapid turnaround service, please contact one our service specialists at: **800-821-5831 option 4.**



Hardy Support locations throughout the United States.

# Appendix A

## List of the Parameter IDs

### Read/Write Parameters

#### Configuration Parameters:

Units	0x2881
Waversaver	0x2081
NumAverages	0x2082
ZeroTolerance	0x2886
AutoZeroTolerance	0x6302
AutoZeroState	0x6301
MotionTolerance	0x2887
SpanWeight	0x4182
RefWeight	0x4101
Gravity Correction	0x4102
Tare Weight	0x6183
Cal Year	0x4202
Cal Month	0x4203
Cal Day	0x4204

#### Diagnostic Write Parameters:

IT_NUMSENSORS JBOX 1	0x498D
IT_NUMSENSORS JBOX 2	0x498E

### Read Only Parameters

#### IT Test Diagnostic Parameters:

IT WEIGHT CHANNEL 0	0x4990
IT WEIGHT CHANNEL 1	0x4991
IT WEIGHT CHANNEL 2	0x4992
IT WEIGHT CHANNEL 3	0x4993
IT WEIGHT CHANNEL 4	0x4994
IT WEIGHT CHANNEL 5	0x4995
IT WEIGHT CHANNEL 6	0x4996
IT WEIGHT CHANNEL 7	0x4997
IT MV/V CHANNEL 0	0x49A0
IT MV/V CHANNEL 1	0x49A1
IT MV/V CHANNEL 2	0x49A2
IT MV/V CHANNEL 3	0x49A3
IT MV/V REF 1	0x49A8
IT MV/V CHANNEL 4	0x49A4
IT MV/V CHANNEL 5	0x49A5
IT MV/V CHANNEL 6	0x49A6

IT MV/V CHANNEL 7	0x49A7
IT MV/V REF 2	0x49A9
IT RAW VARIATION CHANNEL 0	0x49B0
IT RAW VARIATION CHANNEL 1	0x49B1
IT RAW VARIATION CHANNEL 2	0x49B2
IT RAW VARIATION CHANNEL 3	0x49B3
IT RAW VARIATION REF 1	0x49B8
IT RAW VARIATION CHANNEL 4	0x49B4
IT RAW VARIATION CHANNEL 5	0x49B5
IT RAW VARIATION CHANNEL 6	0x49B6
IT RAW VARIATION CHANNEL 7	0x49B7
IT RAW VARIATION REF 2	0x49B9
IT WAVERSAVER VARIATION CHANNEL 0	0x49C0
IT WAVERSAVER VARIATION CHANNEL 1	0x49C1
IT WAVERSAVER VARIATION CHANNEL 2	0x49C2
IT WAVERSAVER VARIATION CHANNEL 3	0x49C3
IT WAVERSAVER VARIATION REF 1	0x49C8
IT WAVERSAVER VARIATION CHANNEL 4	0x49C4
IT WAVERSAVER VARIATION CHANNEL 5	0x49C5
IT WAVERSAVER VARIATION CHANNEL 6	0x49C6
IT WAVERSAVER VARIATION CHANNEL 7	0x49C7
IT WAVERSAVER VARIATION REF 2	0x49C9
IT RAW VARIATION RESULT CHANNEL 0	0x49D0
IT RAW VARIATION RESULT CHANNEL 1	0x49D1
IT RAW VARIATION RESULT CHANNEL 2	0x49D2
IT RAW VARIATION RESULT CHANNEL 3	0x49D3
IT RAW VARIATION RESULT REF 1	0x49D8
IT RAW VARIATION RESULT CHANNEL 4	0x49D4
IT RAW VARIATION RESULT CHANNEL 5	0x49D5
IT RAW VARIATION RESULT CHANNEL 6	0x49D6
IT RAW VARIATION RESULT CHANNEL 7	0x49D7
IT RAW VARIATION RESULT REF 2	0x49D9
IT WAVERSAVER VARIATION RESULT CHANNEL 0	0x49E0
IT WAVERSAVER VARIATION RESULT CHANNEL 1	0x49E1
IT WAVERSAVER VARIATION RESULT CHANNEL 2	0x49E2
IT WAVERSAVER VARIATION RESULT CHANNEL 3	0x49E3
IT WAVERSAVER VARIATION RESULT REF 1	0x49E8
IT WAVERSAVER VARIATION RESULT CHANNEL 4	0x49E4
IT WAVERSAVER VARIATION RESULT CHANNEL 5	0x49E5
IT WAVERSAVER VARIATION RESULT CHANNEL 6	0x49E6
IT WAVERSAVER VARIATION RESULT CHANNEL 7	0x49E7
IT WAVERSAVER VARIATION RESULT REF 2	0x49E9



IT RTZ CHANNEL 0	0x49F0
IT RTZ CHANNEL 1	0x49F1
IT RTZ CHANNEL 2	0x49F2
IT RTZ CHANNEL 3	0x49F3
IT RTZ CHANNEL 4	0x49F4
IT RTZ CHANNEL 5	0x49F5
IT RTZ CHANNEL 6	0x49F6
IT RTZ CHANNEL 7	0x49F7
IT RTZ COMBINED	0x498C

**Stability Test Parameters:**

STABILITY RAW MEAN	0x4901
STABILITY WAVERSAVER MEAN	0x4903
STABILITY RAW VARIATION	0x4902
STABILITY WAVERSAVER VARIATION	0x4904
STABILITY RAW VARIATION RESULT	0x4905
STABILITY WAVERSAVER VARIATION RESULT	0x4906

**Read Only Parameters:**

GrossWeight	0x6081
NetWeight	0x6082
ADC_Counts	0x4907
ADC_CountsRaw	0x4908
CalLowCounts	0x4085
CalHighCounts	0x4087
ZeroCounts	0x2889
CalZeroCounts	0x4084
Cal Type	0x4001
NUMBER C2 SENSORS	0x4103
NUMBER IT J-BOXES	0x4881
FirmwareRevision	0x7985